



ISA 2021

The 19th International Symposium on Atherosclerosis

Sponsorship Prospectus (revised)

Hybrid Symposium

Co-Chairs, Local Organizing Committee

Yasufumi Sato (Tohoku University)

Shizuya Yamashita (Rinku General Medical Center)

Hosted by: Japan Atherosclerosis Society (JAS)



ISA 2021 The 19th International Symposium on Atherosclerosis

<http://www.c-linkage.co.jp/isa2021/>

Toward Healthy Aging through Atherosclerosis Science



INTERNATIONAL
ATHEROSCLEROSIS
SOCIETY

ISA 2021

The 19th International
Symposium on Atherosclerosis
<http://www.c-linkage.co.jp/isa2021/>
Toward Healthy Aging through Atherosclerosis Science

Table of Contents

Invitation to Sponsors	5
Outline of the ISA2021	7
Local Organizing Committee	9
Sponsorship Opportunities	13
Sponsorship: Packages	14
Sponsorship: À La Carte	15
Luncheon Seminar/Sponsored Symposium Prospectus	17
List of Sponsored Seminars and Symposiums	22
Exhibition Prospectus	23
Web Exhibition Prospectus	27
Advertisement Opportunities	30
Advertisement Opportunities (Venue Ad and Others)	32
Sponsorship Application Procedure	33



ISA 2021 The 19th International Symposium on Atherosclerosis

<http://www.c-linkage.co.jp/isa2021/>

Toward Healthy Aging through Atherosclerosis Science



ISA 2021

The 19th International Symposium on Atherosclerosis
<http://www.c-linkage.co.jp/isa2021/>
Toward Healthy Aging through Atherosclerosis Science

Invitation to Sponsors

Dear Valued Corporate Partner/Sponsor,

On behalf of all members of the Japan Atherosclerosis Society and the Organizing Committee of ISA2021, we are delighted to extend an open invitation to you to be a part of ISA2021. The Symposium is scheduled to be held from Sunday, October 24 to Wednesday, October 27, 2021. Many of you may have great memories from the ISA Symposium organized by JAS back in 2003.

The theme for the ISA2021 is ***“Toward Healthy Aging through Atherosclerosis Science”***.

As the premier event in the fields of atherosclerosis, we ensure to make this symposium a great success by offering participants with an invaluable educational experience as well as the opportunity to explore new scientific discoveries and relevant key updates in major areas of the field.

ISA2021 Local Organizing Committee have carefully considered the ways of holding this symposium in response to the global impact of coronavirus (COVID-19). Our top priority will always be the health and safety of the participants and invited faculty, as well as our dedicated corporate sponsors and staff.

After much careful deliberate consideration, ISA2021 Local Organizing Committee decided to change the format to Hybrid format (a blend of in-person in Kyoto and online). We are planning the hybrid format to welcome participants who are unable to attend on site from across the globe.

There are many attractive sponsorship and marketing opportunities available to include you in the program and to increase the visibility of your company’s brand.

We appreciate your understanding of our intention and your generous support.

Cordially yours,

Yasufumi Sato
Co-Chair, Local Organizing Committee
ISA2021

Shizuya Yamashita
Co-Chair, Local Organizing Committee
ISA2021



ISA 2021

The 19th International Symposium on Atherosclerosis
<http://www.c-linkage.co.jp/isa2021/>
Toward Healthy Aging through Atherosclerosis Science



Outline of ISA2021

I. Name of Symposium

The 19th International Symposium on Atherosclerosis (Abbreviation : ISA2021)

II. Organizer

Host: Japan Atherosclerosis Society (JAS)

International Headquarters: International Atherosclerosis Society (IAS)

III. Dates

October 24 (Sun) – October 27 (Wed), 2021 [4 days] *Live streaming and in-person

*On-demand distribution: October 24 (Sun) –November 30 (Tues) (TBC)

IV. Co-located event

The 53rd Meeting of the Japan Atherosclerosis Society

October 23 (Sat) – October 24 (Sun), 2021

V. Holding Method (Venue)

Hybrid Style: Onsite and Online Platform*

(Onsite venue: Kyoto International Conference Center)

VI. Online Platform

An online platform to deliver the live streaming and on-demand program and web exhibition within the official ISA2021 website.

<https://www.c-linkage.co.jp/isa2021/index.html>

VII. Theme

Toward Healthy Aging through Atherosclerosis Science

VIII. Anticipated Number of Participants

3,000 participants (Domestic: 1,000/International: 2,000) 100 countries/area

IX. Symposium Purpose and Scope

The purpose of this symposium is to invite leading experts in the fields of research and treatment of Atherosclerosis and related diseases both domestic and international, to present and discuss the latest advancements in research and innovative treatment of these diseases.



X. About the Program

A. Program (tentative)

Plenary Lecture, Plenary Symposia, Symposia, Guideline Session, Sponsored Seminars/ Symposia, Joint Symposium, Oral & Poster Sessions, Public Forum, Sponsored Sessions (Sponsored Seminar, Morning Seminar, Luncheon Seminar, Evening Seminar), Exhibition (both onsite and web) etc.

B. Official Language

English

C. Proposed Schedule

	24-Oct	25-Oct	26-Oct	27-Oct
AM	(The 53rd Meeting of the Japan Atherosclerosis Society)	(Morning Seminar) Plenary Symposia Symposia Sponsored Symposia	(Morning Seminar) Plenary Symposia Symposia Sponsored Symposia	(Morning Seminar) Plenary Symposia Symposia Sponsored Symposia
PM	Setup	(Luncheon Seminar) Plenary Symposia Symposia Sponsored Symposia	(Luncheon Seminar) Plenary Symposia Symposia Sponsored Symposia	(Luncheon Seminar) Plenary Symposia Symposia Sponsored Symposia
Evening	Opening ceremony Keynote Lecture (Welcome reception)	(Evening Seminar)	(Evening Seminar)	Closing ceremony

D. Key topics

Lipid (Basic, Clinical, Nutrition, Exercise, Familial Hypercholesterolemia), Diabetes (Basic, Clinical, Micro/ Macroangiopathy, Therapeutics), Hypertension, Kidney Disease, Stroke, Cardiovascular Disease, Thrombosis, Obesity/NASH (Nonalcoholic Steatohepatitis), Imaging/ Device, Novel Therapies (including Nucleic Acid Medicine), Vascular Biology, Epidemiology Big Data, Cancer Therapy and Atherosclerosis, etc.



ISA 2021

The 19th International Symposium on Atherosclerosis
<http://www.c-linkage.co.jp/isa2021/>
Toward Healthy Aging through Atherosclerosis Science

Local Organizing Committee

As of May 2021

Co-Chairs

Yasufumi Sato Tohoku University
Shizuya Yamashita Rinku General Medical Center

Advisory Board

Hiroyuki Daida Juntendo University Graduate School of Medicine
Makoto Kinoshita Toray Industries, Inc.
Masayuki Yokode Kyoto University Hospital

Committee Members

Masahiro Akishita The University of Tokyo
Hidenori Arai National Center for Geriatrics and Gerontology
Yujiro Asada University of Miyazaki
Hideaki Bujo Toho University Sakura Medical Center
Kensuke Egashira Kyushu University Graduate School of Medicine
Ken-ichi Hirata Kobe University Graduate School of Medicine
Shun Ishibashi Jichi Medical University
Kouji Kajinami Kanazawa Medical University
Koichi Kozaki Kyorin University School of Medicine
Masafumi Kuzuya Nagoya University
Chizuko Maruyama Japan Women's University
Takashi Miida Juntendo University Graduate School of Medicine
Koichi Node Saga University
Hitoshi Shimano University of Tsukuba
Tetsuo Shoji Osaka City University Graduate School of Medicine
Seiji Umemoto Araki Neurosurgical Hospital
Koutaro Yokote Chiba University Graduate School of Medicine
Masayuki Yoshida Tokyo Medical and Dental University

Sub Committees *Co-Chairs

Sponsorship and Fundraising Committee

*Ken-ichi Hirata Kobe University Graduate School of Medicine

*Koutaro Yokote	Chiba University Graduate School of Medicine
Shinya Goto	Tokai University School of Medicine
Masumi Hara	Mizonokuchi Hospital, Teikyo University School of Medicine
Mariko Harada-Shiba	National Cerebral and Cardiovascular Center Research Institute
Nobuya Inagaki	Kyoto University
Shinji Kihara	Osaka University
Tetsuya Matoba	Kyushu University Hospital
Katsumi Miyauchi	Juntendo Tokyo Koto Geriatric Medical Center
Koichi Node	Saga University
Sumito Ogawa	The University of Tokyo, Japan
Yusuke Ohya	University of the Ryukyus
Kayoko Sato	Tokyo Women's Medical University
Ichiro Shimomura	Osaka University
Kohjiro Ueki	National Center for Global Health and Medicine

Scientific Program Committee

*Yujiro Asada	University of Miyazaki
*Masayuki Yoshida	Tokyo Medical and Dental University
Hidenori Arai	National Center for Geriatrics and Gerontology
Hiroyuki Daida	Juntendo University, Graduate School of Medicine
Jianglin Fan	Faculty of Medicine University of Yamanashi
Satoshi Fujii	Asahikawa Medical University Hospital
Yoshio Fujioka	Kobe Gakuin University
Shinya Goto	Tokai university school of Medicine
Mariko Harada-Shiba	National Cerebral and Cardiovascular Center Research Institute
Hisanori Horiuchi	Aging and Cancer, Tohoku University
Nobuya Inagaki	Kyoto University
Takashi Kadowaki	The University Tokyo/ Teikyo University
Shinji Koba	Showa University School of Medicine
Masahiro Koseki	Osaka University Graduate School of Medicine
Tetsuya Matoba	Kyushu University Hospital
Chizuko Maruyama	Japan Women's University
Masayasu Matsumoto	Sakai City Medical Center
Takashi Miida	Juntendo University Graduate School of Medicine
Toyoaki Murohara	Nagoya University
Koichi Node	Saga University
Yusuke Ohya	University of the Ryukyus
Shinichi Oikawa	Diabetes and Lifestyle Disease Center
Tomonori Okamura	Keio University School of Medicine

Hiromi Rakugi	Osaka University
Yasushi Sakata	Osaka University
Kazunori Shimada	Juntendo University Graduate School of Medicine
Iichiro Shimomura	Osaka University
Kohji Shirai	Toho university
Tetsuo Takehara	Osaka University
Kenichi Tsujita	Kumamoto University
Kazuhisa Tsukamoto	Teikyo University
Kohjiro Ueki	National Center for Global Health and Medicine
Koutaro Yokote	Chiba University Graduate School of Medicine
Yoshikazu Yonemitsu	Kyushu University Graduate School of Pharmaceutical Science
Hiroshi Yoshida	The Jikei University Kashiwa Hospital

Promotion & Marketing Committee

*Kensuke Egashira	Kyushu University Graduate School of Medicine
*Kouji Kajinami	Kanazawa Medical University
Masumi Ai	Tokyo Medical and Dental University
Hironobu Akao	Kanazawa Medical University
Hirotohi Hamaguchi	Kita-Harima Medical Center
Daisaku Masuda	Rinku General Medical Center
Tetsuya Matoba	Kyushu University Hospital
Eriko Morishita	Kanazawa University
Fumitaka Okajima	Chibahokusoh Hospital, Nippon Medical School
Naoya Yahagi	University of Tsukuba

Social/Events Committee

*Hidenori Arai	National Center for Geriatrics and Gerontology
*Masafumi Kuzuya	Nagoya University
Yoshio Fujioka	Kobe Gakuin University
Daisaku Masuda	Rinku General Medical Center
Koh Ono	Kyoto University Graduate School of Medicine
Yukihiko Ueda	KKR Hirakata Kohsai Hospital/ Kyoto University

Onsite Operation Committee

*Masahiro Akishita	The University of Tokyo
*Koichi Kozaki	Kyorin University School of Medicine
Hiroshi Hasegawa	Kyorin University
Sumito Ogawa	The University of Tokyo

Yukihiko Ueda	KKR Hirakata Kohsai Hospital/ Kyoto University
Naoya Yahagi	University of Tsukuba
Hiroshi Yoshida	The Jikei University Kashiwa Hospital

Editorial Committee

*Shun Ishibashi	Jichi Medical University
*Takashi Miida	Juntendo University Graduate School of Medicine
Yoko Fujiwara	Ochanomizu University
Eriko Morishita	Kanazawa University
Hiroaki Okazaki	The University of Tokyo Hospital
Kayoko Sato	Tokyo Women's Medical University
Daisuke Sugiyama	Keio University
Minoru Takemoto	International University of Health and Welfare

Contact Information (Sponsorship Secretariat)

ISA2021 Sponsorship Secretariat

c/o Convention Linkage, Inc.

634 Shichikannon-cho, Nakagyo-ku, Kyoto, 604-8162, Japan

TEL : +81-75-231-6357 FAX : +81-75-231-6354

Email : sp_isa2021@c-linkage.co.jp

Official Website : <http://www.c-linkage.co.jp/isa2021/index.html>

Sponsorship Opportunities

Sponsorship: Packages

Package	Gold	Silver	Bronze
Fees (tax included) USD	110,000	55,000	33,000
No. of Sponsorships Available	Sold out	2	5
Luncheon Seminar or Sponsored Symposium	1	-	-
Luncheon Seminar * Item LS-A or LS-B (detail information in the à la carte menu below) of the sponsor's choice	-	1	1
Onsite Hospitality Suite + Web Exhibition or equivalent floor space	✓ ¹	-	-
Exhibition: Onsite Space (20 m ²) + Web Exhibition	-	✓	-
Exhibition: Onsite Space (10 m ²) + Web Exhibition	-	-	✓
Logo on Lanyard (AD-01)	✓	-	-
Complimentary Registration (40,000 JPY per registration)	10	5	3
Company description and logo with website link on ISA2021's homepage and sponsor's page	✓	✓	✓
Company name shown on slides during intersessions	✓	✓	✓

¹ 1st priority

Sponsorship: À La Carte

[Sponsored Sessions]

**All fees are tax included*

Item No.	Item	Details/Specifications (Tentative)	Fees in USD	Availability
LS-A	Luncheon Seminar A (60min) Onsite 300 seats +webcast	2 rooms: Annex Hall 1/2, Room A	27,500	1
LS -B	Luncheon Seminar B (60min) Onsite 100 seats+webcast	2 rooms: Room B-1, Room B-2	22,000	2
LS-C	Luncheon Seminar C (60min) Onsite 50 seats only	1 room: Room C-1	14,300	2
SS	Sponsored Symposium (90min) Onsite 300 seats+webcast	2 rooms: Annex Hall 1/2, Room A	33,000	1
MS	Morning Seminar (60min) Onsite 100 seats+webcast	2 rooms: Room B-1, Room B-2	11,000	3
ES	Evening Seminar (60min) Onsite 100 seats+webcast	2 rooms: Room B-1, Room B-2	11,000	2

*Please note that **the number of seats available may be further adjusted downward as a safety measure against COVID-19.**

[Exhibition]

Item No.	Item	Details/Specifications	Fees in USD	Availability
HS-01	Hospitality Suite *Onsite +Web Exhibition	50 m ²	55,000	Sold out
EX-01	Space (1 unit= 2 m ²) *Onsite +Web Exhibition	Minimum application: 4 m ²	33,000	10
EX-02	Shell Scheme *Onsite +Web Exhibition	W1,800×D600×H2,100	44,000	5

*There is no discount available in the case that you choose either onsite exhibition only or web exhibition only.

[Advertisement]**All fees are tax included*

Item No.	Item	Details/Specifications	Fees in USD	Availability
AD-01	Logo on Lanyard	Given to the onsite participants	8,800	Sold out
AD-02	Company Ad on the Program at a Glance /Venue Map	Color on the back of cover page of the booklet	3,300	Sold out
		B/W full page inside of the booklet	2,200	3
AD-03	Banner on the Online Platform	Size to be announced	3,300	3
AD-04	Banner on the Official ISA2021 Website	Posted on the official website (until the end of November. 2021) *Size W220 x H48	3,300	3
AD-05	Promotional Video	Promotional video (30 sec) during intersessions; 5 min in total while the symposium in session	3,300	5
AD-06	Logo on Email Newsletter	Sent out once/twice a month, between May 2021 and November, 2021	1,100	2
AD-07	Logo on Webcast Viewing Page	On Online Platform	1,100	2

[Other Advertisement and Service]

Item No.	Item	Details/Specifications	Fees in USD	Availability
VA-01	Banner Ad.	Annex Hall	3,300	2
BR-01	Lounge Service	Annex Hall	5,500	2

Luncheon Seminar/Sponsored Symposium Prospectus

I. Luncheon Seminar Overview

- A. Name: ISA2021 Luncheon Seminar
 - * Joint session of ISA2021 and the respective sponsor
- B. Dates: 25 (Mon) - 27 (Wed) October 2021
- C. Duration of the session: 60 min. (TBC)
- D. Location: Kyoto International Conference Center (ICCK) and Webcast
Takaragaike, Sakyo-ku, Kyoto, 606-0001
URL: <http://www.icckyoito.or.jp/visitor/access/>
- E. Language: English (simultaneous interpretation service available at an additional cost)

II. Sponsored Symposium Overview

- A. Name: ISA2021 Sponsored Symposium
 - * Joint session of ISA2021 and the respective sponsor
- B. Dates: 25 (Mon) -27 (Wed) October 2021
- C. Duration of the session: 90 min. (TBC)
- D. Location: Kyoto International Conference Center (ICCK) and Webcast
Takaragaike, Sakyo-ku, Kyoto, 606-0001
URL: <http://www.icckyoito.or.jp/visitor/access/>
- E. Language: English (simultaneous interpretation service available at an additional cost)

III. Morning Seminar Overview

- A. Name: ISA2021 Morning Seminar
 - * Joint session of ISA2021 and the respective sponsor
- B. Dates: 25 (Mon) -27 (Wed) October 2021
- C. Duration of the session: 60 min. (TBC)
- D. Location: Kyoto International Conference Center (ICCK) and Webcast
Takaragaike, Sakyo-ku, Kyoto, 606-0001
URL: <http://www.icckyoito.or.jp/visitor/access/>
- E. Language: English (simultaneous interpretation service available at an additional cost)

IV. Evening Seminar Overview

- A. Name: ISA2021 Evening Seminar
 - * Joint session of ISA2021 and the respective sponsor
- B. Dates: 25 (Mon) -27 (Wed) October 2021
- C. Duration of the session: 60 min. (TBC)
- D. Location: Kyoto International Conference Center (ICCK) and Webcast
Takaragaike, Sakyo-ku, Kyoto, 606-0001
URL: <http://www.icckyoito.or.jp/visitor/access/>
- E. Language: English (simultaneous interpretation service available at an additional cost)

V. Seminar Formats

Please select one of the following seminar formats.

(1) [Basic plan] Onsite + Live Streaming + On-demand Distribution

- Live streaming of the on-going session.
- Recording of the session available on-demand until November 30, 2021

(2) Onsite + Live Streaming (no recording)

- Live streaming of the on-going session
- No recording (and thus no on-demand service) of the session

(3) Onsite Playback + Online Playback + On-demand Distribution

- Playback of pre-recorded presentation(s) at the designated date/time in the designated seminar room and on the exclusive website
 - No live streaming of the session
 - On-demand service available during the on-demand service period
- *Each company should make the recording and send the video in advance to the Sponsorship Secretariat.

Note:

*Seminars will basically be held both onsite (or onsite playback) and live streaming. There will be no discount applicable to sponsorship fees in the case that you choose either online only or onsite only. (LC-C will be held onsite only.)

*There is a possibility that all seminars are to hold online only, due to matters that are not under the organizer's control such as natural disasters and measures against COVID-19. Under such circumstance, LC-C will also be held online.

*Seminar cancellation due to company-specific reasons will result in a 100% cancellation fee even if ISA2021 changes to a purely virtual format for matters not under the Organizer's control.

VI. Program Contents

Presentation contents, speakers, chairs, date, and room will be determined upon reviewing and discussing the proposals made by each company. Please note that the final decision is to be made by the Local Organizing Committee.

VII. Sponsorship Fee

The sponsorship fee of LS-A, LS-B, SS, MS and ES sessions covers:

- 1 seminar room + 1 waiting room (3 hours, including 1 hour before and 1 hour after the seminar)
- AV equipments (only those equipped at the seminar room)
 - 3 PCs (internal camera) for 1 speaker and 2 chairs,
 - 4 Microphones for 1 speaker, 2 chairs, and 1 floor, and technician at the seminar room.
- PA and lighting equipments (only those equipped in the seminar room)
- Internet connection at the seminar room
- Staging at the seminar room
 - 1 podium for a speaker , table and chairs for chairs (up to 2 persons)
- Right to live stream the session at a specified date and time
- Platform setup for live streaming and on-demand service
- Platform system launch and check-up for live streaming and on-demand service
- Q&A function (comment posting format)
- On-demand service (until November 30): Video-recording the session and uploading the video(s) to the online platform.

The sponsorship fee of LS-C session covers:

- 1 seminar room + 1 waiting room (3 hours, including 1 hour before and after the seminar, respectively)
- AV equipments (only those equipped in the seminar room)
- PA and lighting equipments (only those equipped in the seminar room)

***Please understand there will be no discount applicable in sponsorship fees in case you choose either onsite or online only.**

Please note that the following items **are NOT** included in the sponsorship fee:

- Food & Beverages: Box lunch (at luncheon seminar) and beverages for participants, food and beverages for speakers and chairpersons at pre-meetings, etc.
- Personnel: Operation staff, such as MCs, time keepers, receptionists, ushers in the seminar room, etc.
- Signboard(s): Seminar room signboards, name boards for speakers/chairs, seminar leaflet
- Honorarium/travel/accommodations for speakers and chairs.
- Additional rooms other than the seminar and waiting rooms, such as live streaming room, or pre-recording room
- Additional equipment/devices: Simultaneous interpretation equipment, additional recording devices (cameras/microphones) if needed, equipment in the waiting room,

etc.

- Equipment/devices for pre-recordings and for online participation of chairs/speakers (other than those equipped in the seminar room): PCs (laptops), microphones (internal/external), web cameras (internal/external), and Internet connection.
- Management fee for additional service (15% of the above additional charges). Actual expenses will be invoiced by the Sponsorship Secretariat (Convention Linkage, Inc.) after the Symposium concludes. Details will be announced in the Sponsored Session Guidelines. 15% management fee applies to the extras not to the session itself.

VIII. Invitation to Speakers/Chairs

After the seminar contents are finalized, invitations are to be sent from the sponsor.

*Please send the tentative program to the Sponsorship Secretariat before sending out the invitation.

IX. Printed Materials

A. Abstract(s)

- Abstract(s) will be included in the Web Abstract Book, or on the Online Platform.

B. Seminar Leaflet (optional, all expenses to be covered by the sponsor)

- Size: A4 size or smaller
- No. of volume: at your discretion.

Please submit the proofread manuscript to the Sponsorship Secretariat before printing.

- Logo on the leaflet: The ISA2021 logo file will be provided by the Sponsorship Secretariat.

C. Signboard(s) (optional, all expenses to be covered by the sponsor)

- The Organizer will designate a unified design.

X. Simultaneous Interpretation

A. Interpreters: Sponsors can make their own arrangements, or place an order to the Sponsorship Secretariat.

B. Simultaneous Interpretation Equipment: Please place an order to the Sponsorship Secretariat. All costs must be covered by the sponsor.

XI. Recording:

A. Video recording: Sponsors can make their own arrangements, or place an order to the Sponsorship Secretariat.

Please notify the Secretariat whether the recording will/will not be arranged. We may ask the sponsor to submit an application form.

- B. Recording equipment: Video recording stage, audio line, power supply will be arranged at an additional cost.

XII. Others:

- A. Disclosure of sponsorship fee on the sponsor's website

The Local Organizing Committee agrees that sponsors disclose the sponsorship information on their corporate website (e.g., XXXX JPY for YYYY seminars at ZZZZ symposium) in accordance with the Transparency Guidelines issued by the Japan Pharmaceutical Manufacturers Association (JPMA) and the Japan Federation of Medical Devices Associations (JFMDA), respectively.

To improve the transparency and reliability of the relationship between the member companies of JPMA/JFMDA with medical institutions and medical professionals, both associations have issued their own Transparency Guidelines respectively to urge that their member companies disclose research and development expenses, academic research support expenses, manuscript/writing fees, information provision expenses, and expenses for receptions and social courtesy, etc. paid to medical institutions and medical professionals on their own corporate website.

- B. Cancellation/modification

We may request that sponsors make changes on the specifications such as seminar room equipment/devices, number of seats allowed, or method to hold the seminar, in response to matters that the Organizer should not be held responsible, such as natural disasters and measures against COVID-19.

If the Symposium is to hold purely online in response to matters that the Organizer should not be held responsible, such as natural disasters and measures against COVID-19, all sponsorship applications will automatically be moved to the online format. Please note that in response to the changes mentioned, should sponsors decide not to hold the seminar due to corporate-specific concerns, a 100% cancellation fee will in principle be charged in accordance with the cancellation policy.

List of Sponsored Seminars and Symposiums

* Seating capacity may change.

* All fees are tax included, as of May 2021.

I. Luncheon Seminar (60 min)

Date	Time (TBC)	Capacity/ Fees (Tax included)		
		Approx. 300 seats	Approx. 100 seats	Approx. 50 seats
		27,500 USD	22,000 USD	14,300 USD
Monday, Oct. 25	12:00-13:00	LS-A-1	LS-B-1	LS-C-1
Tuesday, Oct. 26		LS-A-2	LS-B-2	LS-C-2
Wednesday, Oct. 27		LS-A-3	LS-B-3	LS-C-3

II. Sponsored Symposium (90min)

Date	Time	Capacity/ Fee (Tax included)	
		Approx. 300 seats	33,000 USD
Monday, Oct. 25	AM or PM	SS-1	
Tuesday, Oct. 26		SS-2	
Wednesday, Oct. 27	AM	SS-3	

III. Morning Seminar (60 min)

Date	Time	Capacity/ Fee (Tax included)	
		Approx. 100 seats	11,000 USD
Monday, Oct. 25	7:30-8:30	MS-1	
Tuesday, Oct. 26		MS-2	
Wednesday, Oct. 27		MS-3	

IV. Evening Seminar (60 min)

Date	Time	Capacity/ Fee (Tax included)	
		Approx. 100 seats	11,000 USD
Monday, Oct. 25	18:00-19:00	ES-1	
Tuesday, Oct. 26		ES-2	
Wednesday, Oct. 27		ES-3	

* Package sponsors have priority to choose.

Exhibition Prospectus

I. Onsite Exhibition Schedule (Tentative)

[Loading In/Setting Up]	Sun., October 24, 2021, after the 53rd Annual Scientific Meeting of the Japan Atherosclerosis Society
[Exhibition Days]	8:00-17:00 Mon., October 25, 2021 8:00-17:00 Tue., October 26, 2021 8:00-15:00 Wed., October 27, 2021
[Dismantling/Loading Out]	After 15:00 Wed., October 27, 2021

II. Venue: International Conference Center, Kyoto (ICCK) and Web Exhibition

III. Scale of Exhibition: Approx. 17 Exhibitors (TBC)

IV. Exhibitor's eligibility

Companies/organizations in the pharmaceutical and medical device industries that understand the purpose of ISA2021, including pharmaceutical companies, medical device manufacturers, and those whose business is related to pharmaceuticals, medical equipment/devices/tools, reagents, testing equipment, and medical books, etc.

* Exhibitors who plan to exhibit unauthorized items/products under the Pharmaceuticals and Medical Devices Act (PMDA) are required to contact the Sponsorship Secretariat.

* Selling products on site is prohibited, but exceptions may be made upon approval by the Organizer.

V. Hospitality Suite/Exhibition Fees * Package sponsors have priority to choose.

Item No.	Item	Details/Specifications	Fees in USD (Tax included)	Availability
HS-01	Hospitality Suite	Onsite Exhibition (50 m ²) + Web Exhibition	55,000	Sold out
EX-01	Space (1 unit=2 m ²)	Onsite Exhibition (minimum 4 m ²) + Web Exhibition	3,300	10
EX-02	Shell Scheme	Onsite Exhibition + Web Exhibition	4,400	5

* Please refer to the next page for details on specifications of each item.

* There is no discount available in the case that you choose either onsite exhibition only or web exhibition only.

* The holding method may change due to matters that the organizer should not be held responsible, such as natural disasters and measures against COVID-19. If ISA2021 is to hold purely online, all applications will automatically be moved to Web Exhibition.

* Please note that in response to the changes mentioned, should sponsors decide not to hold the exhibition due to corporate-specific concerns, a 100% cancellation fee will in principle be charged in accordance with the cancellation policy.

VI. Details and specifications for Onsite Exhibition

[EX-01] Space Unit 2.0sqm (W2.0m x D1.0m) 3,300 USD /unit (tax included)



- For those who take the space unit, the space is indicated on the floor with marking.
- If the space unit is neighboring to the shell scheme booth, panels are set.
 - *Those who take space unit are required to make minimum decorations/settings.
 - *Sponsors may submit a request for unit size for the Organizer's consideration.

[Activities prohibited]

- The maximum height of decorations/walls for space unit exhibition is 2.5m. If the design requires higher setting, please contact the Sponsor Secretariat.
- In general, direct construction on the floor (adhesive tapes, anchors, etc.) are prohibited.
 - * Additional charge will incur if the company signboard needs to carry a company logo.
 - * Electricity charge as well as costs for electricity work, cleaning, and rubbish disposals will be extra.

[Electricity & Drainage]

- Upon requests from the exhibitors, power will be delivered to the designated booth at extra cost (AC single phase two wire system: 100V60Hz). Please contact the Sponsor Secretariat if needed.
- In general, use of water, gas and compressed air are prohibited.

[EX-02] Shell Scheme Booth (W1800×D600×H2100) 4,400 USD/booth (tax included)

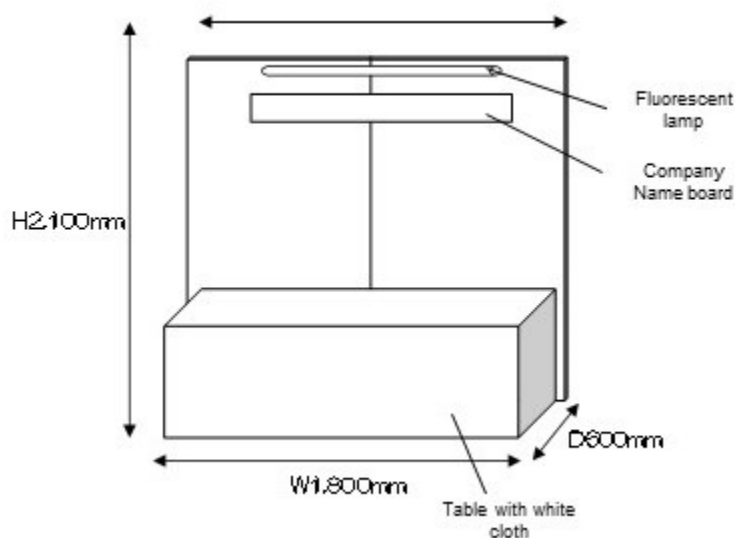

[Basic Specification]

- 1 back panel (octanorm)
- 1 fluorescent lamp
- 1 company name board (W900 x H200: white board, navy letters)
- 1 table (W1800 x D600 x H700: with white cloth)

[EX-02] Items included in the exhibition costs

Management fees from the setting up to dismantling period, and exhibition fees during ISA2021.

- * Additional charge will incur if the company signboard needs to carry a company logo.
- * Electricity charge as well as costs for electricity work, cleaning, and rubbish disposals will be extra.

VII. Allocation of booth

- The Organizer will allocate booth after the application deadline, taking items to be exhibited, number of booths/spaces applied, activities inside of the booth (e.g., hands-on) into consideration, and notify the exhibitors. Please note that the Organizer's decision is final and no objections acceptable.
- Exhibitors are not allowed to exchange their booth locations with others or provide part of their booth space to others without consent of the Organizer.

VIII. Exhibitors from overseas

The exhibition hall is not bonded. All overseas items to be exhibited should undergo the appropriate customs clearance procedures so that such items may be treated as domestic cargo, as well as, if necessary, obtaining an ATA Carnet. Please contact the Sponsorship Secretariat for details.

IX. Exhibition Briefing

No exhibition briefing will be held. Details of booth allocation, instructions for decoration and loading will be announced approx. 2 months prior to the exhibition. Items for rental

equipments will also be informed at that time.

X. Management of the booth

We will provide best protection and management concerning the preservation of exhibition hall and exhibits. However, except for cases not attributable to the Exhibitor, the Organizer and the Symposium Secretariat declines all responsibility for any damage to the exhibits including those caused by natural disasters or force majeure, or any accident to the exhibits.

XI. Measures against COVID-19

During exhibition, exhibitors should take measures against COVID-19 in accordance with the standards of Kyoto Prefecture/City and Kyoto International Conference Center. The guidelines will be announced later in the Exhibition Guidelines.

XII. Others

Exhibitor Pass will be given to exhibitors to enter the exhibition hall. Exhibitor Pass cannot be used to attend the scientific program (lectures, seminars, etc.) of the Symposium. Should you wish to attend the scientific program, please register for the Symposium.

*1 account to access the online platform will be provided.

Web Exhibition Prospectus

I. Media: Web exhibition on the online platform of the 19th International Symposium on Atherosclerosis (ISA2021)

II. Participants: Approx. 3,000 participants, including those who have registered for ISA2021 and possess a login password as well as officers and related personnel of IAS (Domestic: 1,000 participants, International: 2,000 participants)

III. Viewing period: Sun., October 24, 2021–17:00 of Tue., November 30, 2021 (TBC)

IV. Exhibition Contents (TBC)

* Details will be announced later in the Web Exhibition Guidelines.

Exhibition Contents	Gold	Silver	Bronze	Web Exhibition
List of Exhibitors Page				
Company Name	✓	✓	✓	✓
Logo	Extra Large	Large	Medium	Small
Company/Product Introduction (40 words)	✓	✓	n/a	n/a
Link to Detailed Descriptions	✓	✓	✓	n/a
Product Introduction Page				
Company Name	✓	✓	✓	✓
Logo	✓	✓	✓	✓
Company / Product Introduction (200 words)	✓	✓	✓	✓
Contact Information	✓	✓	✓	✓
Link to External Website	✓	✓	✓	✓
Product Image	Up to total 6 items	Up to total 4 items	2 items	2 items per unit (Total 10 max.)
Product Video			n/a	n/a
Product Introduction Text (Up to 300 words per item)	Up to 6 items	Up to 3 items	Up to 2 items	Same as total no. of units
Company Brochure	✓	✓	n/a	✓
Inquiry Form Settings	✓	✓	n/a	✓
Link to Web Meeting (Exhibitors must provide access to their own web meeting.)	✓	✓	✓	n/a

V. Image of Web Exhibition *For illustration purpose only

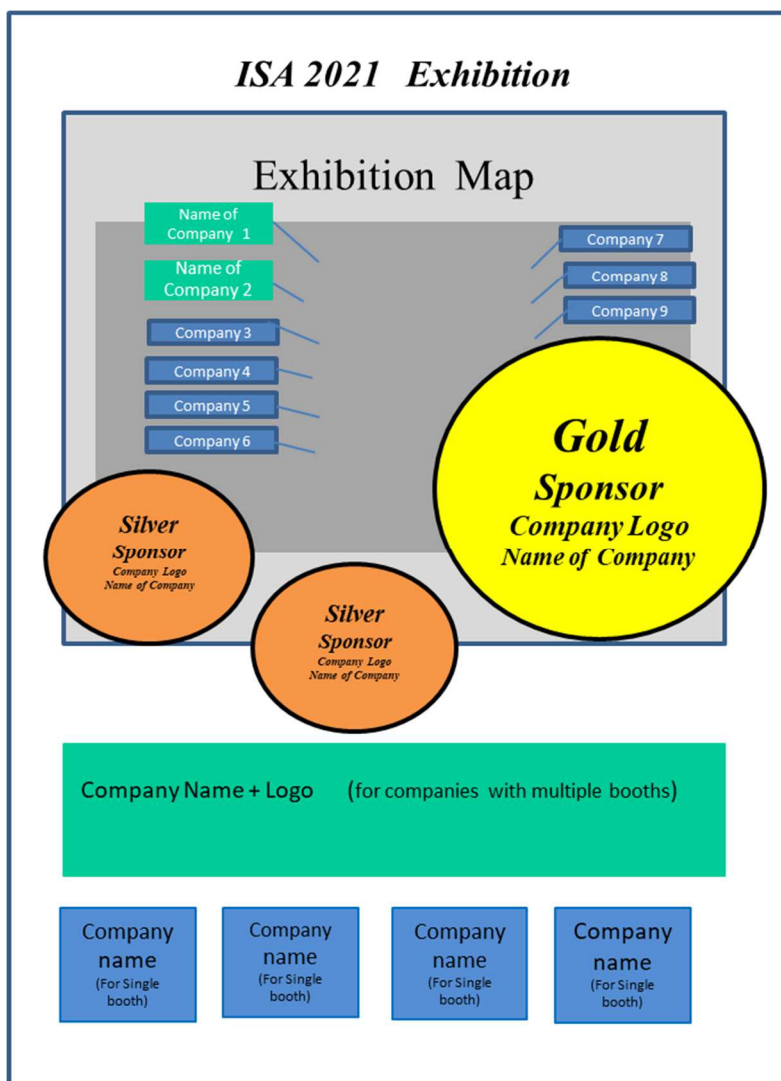

【Application Frame】

- Yellow: Gold Sponsor
Company Logo and Name
- Orange: Silver Sponsor
Company Logo and Name
- Green: Multiple booths company
- Blue: Single shell scheme company

※Booth layout and color are tentative.
It may differ from the color scheme on the actual website.

*Please refer to the Web Exhibition Guidelines, which will be released approx. 3 months prior to the Symposium

VI. About the manuscript

- English is the official language of the Symposium. Please prepare the manuscript in English, or in both English and Japanese.
- We will inform each exhibitor approx. 3 months before the Symposium regarding the method to upload data for web exhibiton, data standards, etc.
- If the content does not match the general brand or values of the Symposium, the Organizer may ask you to correct or withdraw the manuscript. Please note that if you do not respond to the changes requested by the Organizer, the Sponsorship Secretariat may delete the relevant text or make the page unviewable.

- The submitted data will not be used for anything other than ISA2021 Web Exhibition and promotional activities. Data will be deleted promptly after the exhibition ends.

VII. Deadline to submit the manuscript

Thursday, 30 September, 2021 (Tentative)

VIII. Exhibition Date Change, if needed

The online platform (and thus the Web Exhibition) will open from Oct. 24, 2021 (the first day of the Symposium) to November 30, 2021 (the last day of the on-demand distribution). Please inform the Sponsorship Secretariat if your desired exhibition dates differ.

IX. Access to the Web Exhibition Page

- Access to the online platform will be given to exhibitors. The number of accounts given to each exhibitor depends on the number of the units applied, respectively. Each account provides one person with one access to all online programs, including web exhibitions.
- It is strictly prohibited to transfer account information (ID and password) to a third party without permission of the Organizer.
- Multiple people accessing the same account is not allowed. If multiple people wish to view the programs, please each register for the Symposium on the official web site of ISA2021.

Advertisement Opportunities

I. [AD-01] ~~Logo on the Lanyard + Privilege: Logo on Online Platform to Download Registration Cards~~ (Sold Out)

- A. Target: Onsite participants of ISA2021
- B. No. of production: 1,300 (TBC)
- C. Costs: 19,800 USD (tax included)
- D. Sponsorship fee and availability: 8,800 USD (tax included): 2 available,
Total amount for sponsorship: 17,600 USD

II. [AD-02] Company Ad on the Program at a Glance/Floor Map + Privilege: Logo on Online Platform

- A. Target: Onsite participants of the ISA2021
- B. No. of production: 1,300 (TBC)
- C. Cost: 11,000 USD (tax included)
- D. Sponsorship Fee and availability: Total 9,900 USD
 - 1. ~~One page color Ad on the back page: 3,300 USD (tax included),~~
1 available (Sold Out)
 - 2. One page B/W Ad inside the program: 2,200 USD (tax included) , 3 available
- E. Size: A5 size (Details will be informed upon receipt of application)

III. [AD-03] Banner on Online Platform

- A. Media: ISA2021 Online Platform
- B. Cost: 44,000 USD (tax included)
- C. Sponsorship Fee and availability: 3,300 USD (tax included), 3 available
Total sponsorship fee: 9,900 USD (tax included)
- D. Specification: Banner data must be provided by the sponsor.

IV. [AD-04] Banner on ISA2021 Official Website

- A. Media: ISA2021 Official Website
- B. Cost: 22,000 USD (tax included)
- C. Sponsorship Fee and availability: 3,300 USD (tax included), 3 available
Total sponsorship fee: 9,900 USD
- D. Specification: Data must be provided by the sponsor.
 - Size: W220 x H48 pixel
 - Format: GIF (animation allowed), JPEG
- E. Period: Upon receipt of data and fee until the end of Symposium (TBC)

* Data must be sent to the Sponsorship Secretariat by email attachment or CD-R.

V. [AD-05] Promotional Video

- A. Media: ISA2021 Venue & Online Platform
- B. Sponsorship Fee and availability: 3,300 USD (tax included), 5 available
Total sponsorship fee: 16,500 USD
- C. Specification: Video must be provided by the Sponsors.
 - Format: MP4 video file, within 30 sec.
- D. Period: More than 5 min. broadcast during the Symposium

VI. [AD-06] Logo on Email Newsletter

- A. Media: ISA2021 Email Newsletter
- B. Sponsorship Fee and availability: 1,100 USD (tax included), 2 available
Total sponsorship fee: 2,200 USD
- C. Specification: TBC
- D. Period: Once/twice a month, total approx. 10 times between May and November, 2021 (TBC)

ex.

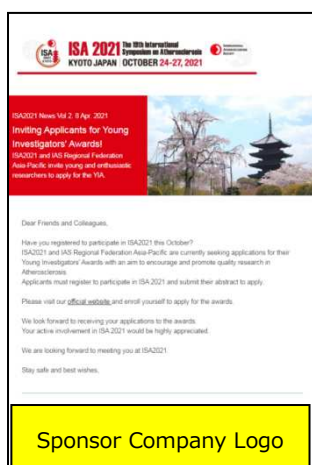

VII. [AD-07] LOGO on Webcast Viewing Screen

- A. Media: ISA2021 Online Platform: Webcast Viewing Screen
- B. Sponsorship Fee and availability: 1,100 USD (tax included), 2 available
Total sponsorship fee: 2,200 USD
- C. Specification: TBC
- D. Period: During the Symposium and until the end of on-demand distribution.

Image.

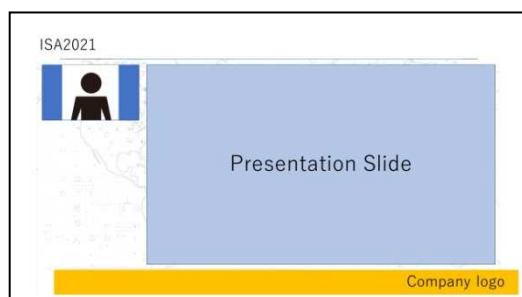

Advertisement Opportunities (Venue Ad and Others)

I. [VA-01] Banner Ad.

- A. Location: ISA2021 Exhibition Hall
- B. No. of production: 2 banners (material: mesh tarpaulin)
- C. Cost: 8,800 USD (tax included)
- D. Sponsorship Fee: 3,300 USD (tax included), 2 available (TBC),
Total sponsorship fee: 6,600 USD
- E. Size: W1500 x H3000

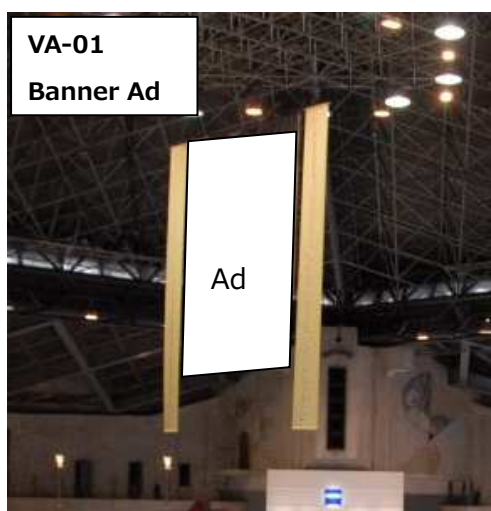

*** Data must be sent to the Sponsor Secretariat by email attachment or CD-R.**

II. [BR-1] Lounge Service

- A. Target: Onsite participants of the ISA2021
- B. Details: Drink service at the lounge space (water), Outlets
 - *Drink service may be cancelled as a preventive measure against COVID-19.
 - *Acknowledgement on the signboards and hall announcements
 - *Company logos to be shown on the table
- C. Locations: Lounge Space in Annex Hall of ICCK
- D. Dates: Monday, October 25 – Wednesday, October 27, 2021
- E. Costs: 15,000 USD (3 days total)
- F. Sponsorship Fee and availability: 5,500 USD (tax included), 2 available
Total sponsorship fee: 11,000 USD



Sponsorship Application Procedure

I. Application

Fill out the application form and submit to the Sponsorship Secretariat by email.

If you do not receive a reply within 10 days of submission, please contact the Sponsorship Secretariat.

Application Period:

Sponsorship Package and Sponsored Sessions

~~1st Closing date: December 20, 2019~~

~~2nd Closing date: March 30, 2020~~

~~3rd Closing date: September 30, 2020~~

~~4th Closing date: November 30, 2020~~

5th Closing date: May 14 (Fri), 2021

Sponsorship Items (Exhibition and Advertising)

~~1st Closing date: December 18, 2020~~

2nd Closing date: May 31 (Fri), 2021

Application may close when the expected number of applications are received.

Payment Method:

Upon receipt of application, an invoice will be issued by the Sponsorship Secretariat.

The payment is due within 30 days from the date of invoice.

Please use the bank transfer receipt as your receipt.

Payments must be net of all charges and bank charges must be borne by the sponsor.

No check will be accepted.

Name of Bank: MUFG Bank, Ltd.

SWIFT CODE/BIC : BOTKJPJT

Bank Code: 0005

Branch Name: Roppongi

Branch Number: 045

Account Type: Ordinary Account

Account Number: 0767832

Account Name: ISA2021

Cancellation and withdrawal:

- A. As a general rule, we cannot accept cancellation after receiving the application form. However, if you wish to cancel due to unavoidable reasons, please explain the situation in writing and obtain the approval from the Organizer.
- B. Dates and venue may change due to unexpected reasons. However, this cannot be used as a reason for cancellation or withdrawal. Any costs caused by this change will not be reimbursed.

II. Applications to be sent to:

ISA2021 Sponsorship Secretariat

c/o Convention Linkage, Inc.

634 Shichikannon-cho, Karasuma-dori Rokkaku-sagaru, Nakagyo-ku, Kyoto 604-8162,
Japan

Tel: +81-75-231-6357 Fax: +81-75-231-6354

Email : sp_isa2021@c-linkage.co.jp

Official Website: <http://www.c-linkage.co.jp/isa2021/jp/index.html>